



## 佛山市松可包装机械有限公司

Foshan Soonk Packaging Machine Co.,Ltd.

地址: 广东省佛山市南海区桂城石肯三村文海围外围工业区厂房  
 Add: Fourth and fifth Floor of Factory Building, Weihaiwei Industrial Zone, Third Shiken Village, Guicheng, Nanhai, Foshan, Guangdong, China

公司电话/Tel: +86-757-81859859

公司传真/Fax: +86-757-81859869

销售热线: 4008433188

国内销售电话/Domestic Department Tel: +86-757-63309922

国外销售电话/Export Department Tel: +86-757-63309933

售后服务电话/After Service Tel: +86-757-88726511

投诉电话/Complaint Tel: +86-18902413611

<http://www.songkepack.com>

E-mail: [sales@songkepack.com](mailto:sales@songkepack.com)

注: 机器外形以实物为准, 如有改变, 恕不另行通知



松可包装机械



产品推广手册

2017 product promotion manual



# SOONK PACK

Foshan Soonk Packaging Machine Co.,Ltd.

<http://www.songkepack.com>



## SK-L380 立式自动包装机

SK-L380 Vertical Automatic Packaging Machine



### 主要结构和性能特点 Features

1. 本机结构紧凑，牢固，操作简单，维护方便。
2. 本机采用可编程程序控制系统，超大触摸屏，直观，易懂。
3. 采用伺服运膜系统，定位准确，包装美观。
4. 全自动从计量，充填，制袋，日期打印到产品输送一次完成。
5. 根据客户需要有单包及多连袋切断功能，可配置打孔装置。

1. Featured with compact structure, stable, simple operation, convenient on repairing.
2. Adopts programmable control system, super large touch screen, visual and understandable.
3. Servo film transporting system for accurate positioning, the bag is looking nice.
4. It can finish automatically all processes, from measuring, filling, bag forming, date printing and finished goods conveyance.
5. Single bag or linking bags are available according to customers' request. Hole punch function is also an option.

### 适用范围 Applications

选配不同的计量装置，可包装各种不同种类的物料。

Suitable for packing different kinds of product with different metering devices.



### 可适合的配套 Optional devices



1. 电脑组合称  
Electronic Weighing System



2. 量杯计量机  
Volumetric Cup Metering Device



3. 半自动投料输送机  
Semi-automatic Feeding Device

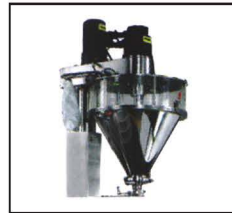

4. 螺旋式计量机  
Auger Filler



5. 液体罐装计量机  
Liquid Filling and Weighing Device

### 技术规格 Specifications

型号 Model	SK-L380
耗气量 Air Consumption	0.65Mpa, 2.5M <sup>3</sup> /min, 6kg/cm <sup>2</sup>
包装薄膜宽度 Packing Film Width	120-380mm
制袋长度 Bag Length	80-240mm
制袋宽度 Bag Width	50-180mm
卷材最大外径 Packing Film Roll Diameter	Max. 300mm
包装速度 Packing Speed	5-85bags/min
包装薄膜厚度 Packing Film Thickness	0.04-0.08mm
电源规格 Power Supply	220V, 50/60Hz, 2.4Kw
机器尺寸 Machine Size	(L)1200x(W)820x(H)1350
机器净重 Machine Net Weight	350kg

### 封口形式 SEALING FORM

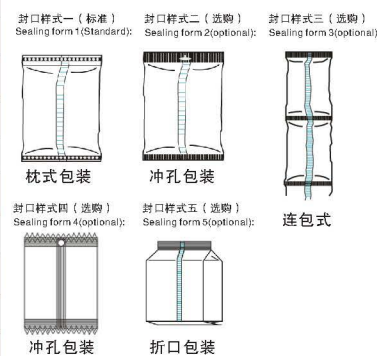

## SK-L380 BT链斗式半自动配套体系

SK-L380BT Semi-automatic Vertical Form-Fill-Seal Machine



### 主要结构和性能特点 Features

1. 设计简单、合理、性能稳定，噪音低，易维护，链斗式传送。
2. 人工计量投料包装，链斗式投料方便投奖卡，奖品或多种物料同时包装。
3. 没有物料时机器不会出空袋，损耗少。
4. 整套配置经济实惠

1. Compact and rational structure, stable performance, low noise, easy maintenance.
2. Metering by hand and feeding with bucket chain conveyor, which is convenient to input prize, lottery and uneasy measuring material or multi-type packing products.
3. It is no empty bags will be formed when there is no material, less waste.
4. The complete set is economical and practical.

### 适用范围 Applications

适合包装易碎或不易计量物料，如：薯片、虾片、薯条、果冻、水饺、汤圆、糖果、干货、油炸食品、五金配件、塑料配件、玩具等  
Suitable for packing frangible product or the goods which are hard on automatic metering, such as potato chips, prawn cracker, fruit flake, jelly, dumpling, candy, dry food, fried food, hardware, accessories, toys and so on.

### 本套机组 Complete set of this machine

1. SK-L380主机 SK-L380 basic packer
2. 链斗式输送机 Bucket chain conveyor
3. 成品输送机 Finished product conveyor

## SK-L380ZT容积计量包装体系

SK-L380ZT Volumetric Cup Metering Automatic Packaging System



### 主要结构和性能特点 Features

1. 全自动完成送料、计量、充填、制袋、打印日期、产品输出全部生产过程。
2. 整套机器的设计简单、合理、性能稳定、易操作、方便日常维护。
3. 可根据物料改装开合门方式计量装置。

1. It can finish automatically all processes, ex. feeding, measuring, filling and forming bag, printing date, product output and counting.
2. The machine structure is compact, rational, stable performance, easy operation and day-to-day maintenance.
3. Volumetric cup metering device can option with valve according to material.

### 适用范围 Applications

适合包装不易碎和易计量规则形状物料，如大米、豆类、种子、瓜子、炒货、膨化食品、糖果、食盐、味精、洗衣粉、饲料等  
Suitable for packing non-frangible product which is with regular shape. Such as rice, beans, roasted seeds and nuts, puffy food, candy, salt, monosodium glutamate, laundry powder etc.

### 本套机组 Complete set of this machine

1. SK-L380主机 SK-L380 basic packer
2. 量杯计量机 Volumetric cup metering device
3. 大斗提升机 Simple raw material elevator
4. 成品输送机 Finished product conveyor



## SK-L420 立式自动包装机

SK-L420 Vertical Automatic Packaging Machine



### 主要结构和性能特点 Features

1. 全自动完成送料、计量、充填制袋、打印日期、产品输出全部生产过程。
2. 计量精度高、效率快、不碎料。
3. 省人工，损耗小，易操作和维护。
4. 单拉膜。
1. It can finish automatically all processes, from measuring, filling, bag making, date stamp and finished goods conveyance.
2. High measuring accuracy, high efficiency, no broken material
3. Less manpower, less waste, easy operation and maintenance.
4. Single belt pulling film

### 技术规格 Specifications

型号 Model	SK-L420
耗气量 Air Consumption	0.65Mpa, 3m <sup>3</sup> /min, 6kg/cm <sup>2</sup>
包装薄膜宽度 Packing Film Width	180-420mm
制袋长度 Bag Length	80-300mm
制袋宽度 Bag Width	80-200mm
卷材最大外径 Packing Film Roll Diameter	Max. 360mm
包装速度 Packing Speed	5-80bags/min
包装薄膜厚度 Packing Film Thickness	0.04-0.08mm
电源规格 Power Supply	220V, 50/60Hz, 2.4Kw
机器尺寸 Machine Size	(L)1100x (W)925 x(H)1650
机器净重 Machine Net Weight	450kg

### 封口形式 SEALING FORM

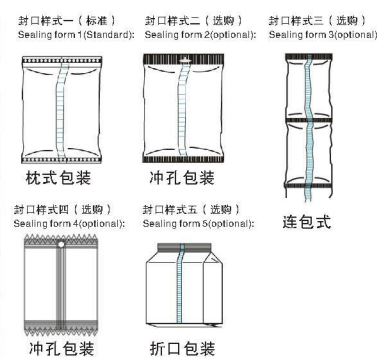

液体自动包装体系  
Liquid automatic packaging machine system

### 本套机组 Complete set of this machine

1. SK-L420 主机 SK-L420 basic packer
2. 十头电子秤 Ten head combined weigher
3. Z型上料机 Z type material conveyor
4. 振动喂料机 Vibrating feeding machine
5. 支撑平台 Supporting platform
6. 成品输送机 Finished product conveyor

### 适用范围 Applications

适合不规则，计量精度高或易碎的散状物品包装。如：薯片，香蕉片，苹果片，锅巴，饼干，花生，瓜子，糖果，坚果，食盐，食糖，速冻食品，蔬菜，五金件，塑料配件等。  
Suitable for packing fragile bulk material with irregular shapes and requiring high measuring accuracy, such as: prawn cracker, potato chips, banana chips, crispy rice, biscuit, peanut, roasted seeds, sweets, nuts, salt, sugar, frozen food, vegetable, hardware, plastic parts accessories etc.

## SK-L420 BT 链斗式半自动配套体系

SK-L420BT Semi-automatic vertical form-fill-seal Machine



### 主要结构和性能特点: Features

1. 设计简单、合理、性能稳定，噪音低，易维护，链斗式传送。
2. 人工计量投料包装，链斗式投料方便投奖卡，奖品或多种物料同时包装，没有物料时机器不会出空袋，损耗少，整套配置经济实惠。
1. Compact and rational structure, stable performance, low noise, easy maintenance, bucket chain conveyor transporting.
2. Metering by hand and feeding with bucket chain conveyor, which is convenient to input prize card, lottery and uneasy measuring material or multitype packing products. It is no empty bags will be formed when there is no material, less waste. The complete set is economical and practical.

### 适用范围: Applications

适合易碎不易自动计量物品如：薯片、馍皮、锅巴、果冻、茶叶、水饺、汤圆等。  
Suitable for packing fragile material and uneasily metering goods such as potato chip, crispy rice, fruit jelly, tea, dumpling, etc.,

## SK-L420FT 螺杆计量包装配套体系

SK-L420FT Vertical Form-Fill-Seal Machine for powder



### 主要结构和性能特点 Features

1. 通过伺服电机带动螺杆旋转达到计量充填物料的目的，具有动作灵敏、计量速度快、精度高、性能稳定等优点。
2. 用于计量易流动或流动性较差的粉类物料。
3. 不锈钢开启式料箱清理方便，符合企业安全卫生管理要求。
1. Auger filler is driven by servomotor to reach the goal of mixing, metering and filling material. Have advantage of sensitive operation, quick measuring, high precision and stable performance.
2. Suitable for metering flow property powder.
3. Stainless open type material box, which is convenient to clean and meet the requirements of enterprise safety and health management.

### 适用范围 Applications

适用包装奶粉、豆奶粉、咖啡粉、淀粉、面粉、黄豆粉、绿豆粉、洗衣粉...  
Suitable for packing milk powder, coffee powder, flour, starch, washing powder and so on.

### 本套机组 Complete set of this machine

1. SK-L420 主机 basic packer
2. 螺旋计量机 Auger filler
3. 螺旋送料器 Screw conveyor
4. 成品输送机 Finished product conveyor



## SK-L420 立式自动包装机

SK-L420 Vertical Automatic Packaging Machine



### 主要结构和性能特点 Features

1. 两侧拉膜、伺服系统定位, 确保纸膜传送平稳, 成袋平整。
  2. 两个独立封口气缸, 确保成袋具有密封性好、封口纹路清晰。
  3. 进口PLC控制、彩色触摸屏, 自动化程度高, 操作、维护方便。
  4. 采用外置式放膜机构, 包装膜安装更简单、更快捷。
1. Two synchronous belts device and servomotor film transporting system, makes the film move stably and form bag smoothly.
  2. Two independent sealing cylinders, the final bag is excellent airtight and nice sealing stripes.
  3. Adopt imported PLC and color touch screen, human-machine interface, high automation, easy to learn and operate, daily maintenance is convenience.
  4. External film feeding mechanism. Film setting is easier and faster.

### 适用范围 Applications

选配不同的计量装置, 可包装各种不同种类的包装。  
Suitable for packing different kinds of product with different metering devices.



### 可适合的配套 Optional devices



1. 电脑组合称  
Electronic Weighing System



2. 量杯计量机  
Volumetric Cup Metering Device



3. 半自动投料输送机  
Semi-automatic Feeding Device

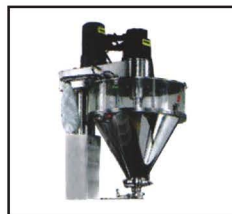

4. 螺旋式计量机  
Auger Filler



5. 液体罐装计量机  
Liquid Filling and Weighing Device

### 技术规格 Specifications

型号 Model	SK-L420
耗气量 Air Consumption	0.65Mpa, 3m <sup>3</sup> /min, 6kg/cm <sup>2</sup>
包装薄膜宽度 Packing Film Width	180-420mm
制袋长度 Bag Length	80-300mm
制袋宽度 Bag Width	80-200mm
卷材最大外径 Packing Film Roll Diameter	Max. 360mm
包装速度 Packing Speed	5-80bags/min
包装薄膜厚度 Packing Film Thickness	0.04-0.08mm
电源规格 Power Supply	220V, 50/60Hz, 3Kw
机器尺寸 Machine Size	(L)1450x (W)1000 x(H)1650
机器净重 Machine Net Weight	500kg

### 封口形式 SEALING FORM

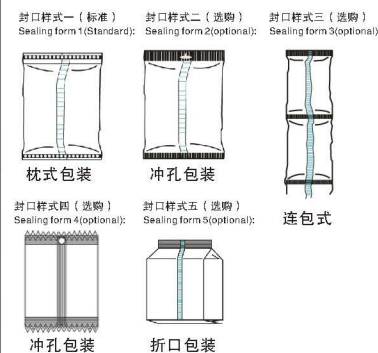

## SK-L420ST 电子称量全自动配套体系

SK-L420ST Vertical form-fill-seal machine with four head linear weigher



### 主要结构和性能特点 Features

1. 高精度数字式传感器、配有四个称量斗, 使准确计量得以瞬间实现。
  2. 微电脑控制系统, 采用双振动给料, 技术先进, 操作简单。
  3. 计量斗易于拆装, 快速简单, 便于清洗维护。
1. Four hoppers with high precision digital sensor. Make weighing more accuracy.
  2. Microcomputer control system, adopting the double vibration feeder, easy operation.
  3. The metering hopper discharge easily, fast, simple and low maintain.

### 适用范围 Applications

适合包装小颗粒及流动性好的粉剂, 如: 白糖、洗衣粉、味精、鸡精、茶精、咖啡、芝麻、种子、大米等相类似物品。  
Suitable for packing small granule and free flowing powder, such as: sugar, washing powder, monosodium glutamate, tea powder, coffee, sesame, seeds, rice etc.

### 本套机组 Complete set of this machine

1. SK-420主机 SK-420 basic packer
2. 四头电子秤 Four head linear weigher
3. 大斗提升机 Simple raw machine elevator
4. 成品输送机 Finished product conveyor

## SK-L420DT 组合称量全自动包装机体系

SK-L420DT Combined Weighing Full Automatic Packaging System



### 主要结构和性能特点 Features

1. 全自动完成送料, 计量, 充填制袋, 打印日期, 产品输出全部生产过程。
  2. 计量精度高, 效率快, 不碎料。
  3. 省人工, 损耗小, 易操作和维护。
1. It can finish automatically all processes, from feeding, measuring, filling, bag making, printing date, product output and counting in one operation.
  2. High measuring accuracy, high efficiency, no broken material.
  3. Less manpower, less waste, easy operation and maintenance.

### 适用范围 Applications

包装范围在1000ml以内的产品, 适合不规则, 计量精度高及容易碎的散状物品包装中, 如: 膨化食品、虾条、薯片、香蕉片、苹果片、锅巴、饼干、花生、瓜子、糖果等。  
Suitable for packing fragile bulk material with irregular shapes and requiring high measuring accuracy, such as: puffed food, potato chips, banana chips, apple flakes, crispy rice, biscuit, chocolate ball, cooked seeds, roasted nuts, sweets, sugar, candy, hardwares etc.

### 本套机组 Complete set of this machine

1. SK-L420主机 SK-L420 basic packer
2. 十头电子秤 Ten head combined weigher
3. Z型上料机 Z type material conveyor
4. 振动喂料机 Vibrating feeding machine
5. 支撑平台 Supporting platform
6. 成品输送机 Finished product conveyor



## SK-L520立式自动包装机

SK-L520 Vertical Automatic Packaging Machine



## SK-L520WF往复式立式包装机

SK-L520WF Reciprocating type vertical form packaging machine



### 主要结构和性能特点Features

1. 采用彩色中英文触摸屏和进口PLC控制，操作方便、直观高效。
2. 气路控制和电路控制独立分离，噪音小，电路更稳定。
3. 采用真空双皮带伺服电机拉膜：拉膜阻力小，实现高精度定位，尺寸准确，包装袋成型好，更美观，皮带不易磨损。
4. 采用外置式放膜机构，包装膜安装更简单、更容易。
5. 整机采用封闭式机构，有效防止粉尘进入机器内部。
6. 本机与计量装置相配套，自动完成送料、计量、充填制袋、打印日期、充气（排气）、成品输送的全过程。

### 适用范围Applications

选配不同的计量装置，可包装各种不同种类的包装。

Suitable for packing different kinds of product with different metering devices.



1. Imported PLC and color touch screen, human-machine interface, easy operation, intuitionistic and efficient.
2. Separate pneumatic control and power control, noise is low, and the circuit is more stable.
3. Vacuum film feeding device and two synchronous belt device with servo control system, less film pulling resistance, high orientation precision, bag design can be kept well. And belts are more durable.
4. External film feeding mechanism. Film setting is easier and faster.
5. Close down type mechanism, defending dust into inside of machine.
6. Works with metering device, it can complete the whole procedure of metering, filling, bagging, date printing, exhausting, counting automatically.

### 可适合的配套 Optional devices



2. 量杯计量机  
Volumetric Cup  
Metering Device



3. 半自动投料输送机  
Semi-automatic  
Feeding Device



5. 液体罐装计量机  
Liquid Filling and  
Weighing Device

### 技术规格Specifications

型号 Model	SK-L520	SK-L520WF
耗气量 Air Consumption	0.65Mpa, 4M <sup>3</sup> /min, 6kg/cm <sup>2</sup>	0.65Mpa, 4M <sup>3</sup> /min, 6kg/cm <sup>2</sup>
包装薄膜宽度 Packing Film Width	Max 520mm	Max 520mm
制袋长度 Bag Length	80-350mm	80-350mm
制袋宽度 Bag Width	100-250mm	100-250mm
卷材最大外径 Packing Film Roll Diameter	Max. 360mm	Max 360mm
包装速度 Packing Speed	5-70bags/min	5-70bags/min
包装薄膜厚度 Packing Film Thickness	0.04-0.08mm	0.04-0.08mm
电源规格 Power Supply	220V, 50/60Hz, 3Kw	220V, 50/60Hz, 3kw.
机器尺寸 Machine Size	(L)1430x(W)1200x(H)1700	(L)1550x(W)1200x(H)1800
机器净重 Machine Net Weight	650kg	650kg

## SK-L520FT螺杆计量自动包装体系

SK-L520FT Vertical Form-Fill-Seal Machine for Powder



### 主要结构和性能特点 Features

1. 螺杆计量装置为SS304开启式料仓，日常清理，维修方便。
  2. 伺服控制计量系统实现精度高，计量快，噪音低等优点。
  3. 本机可从制袋，计量，充填，封合，打码到切袋一次性自动完成。
1. Open type SS304 auger filler, easy for daily cleaning and convenience for maintenance.
  2. Servo control system, fast metering, high accuracy and low noise.
  3. This machine completes the whole packing procedure of measuring, loading materials, bagging, date printing, exhausting and products transporting automatically as well as counting.

### 适用范围Applications

适用于奶粉、豆奶粉、咖啡粉、淀粉、面粉等产品的包装。  
Suitable for packing milk powder, soy milk powder, coffee powder, starch and flour etc.

### 本套机组Complete set of this machine

1. SK-L520 主机 SK-L520 basic packer
2. 螺旋计量机 Auger filler
3. 螺旋送料机 Screw conveyor
4. 成品输送机 Finished product conveyor

## SK-L520BT组合称量全自动包装体系

SK-L520BT Combined Weighing Full Automatic Packaging System



### 主要结构和性能特点Features

1. 设计简单、合理、性能稳定，噪音低，易维护，链斗式传送。
  2. 人工计量投料包装，链斗式投料方便投奖卡，奖品或多种物料同时包装，没有物料时机器不会出空袋，损耗少，整套配置经济实惠。
1. Compact and rational structure, stable performance, low noise, easy maintenance, bucket chain conveyor.
  2. Feeding and packaging with manual metering, the bucket chain conveyor is convenient on feeding. The award card, award or several kinds of material can be packaged at the same time, no empty bags will be delivered when there is no material, less waste, complete set of the machine is economical and practical.

### 适用范围Applications

适合易碎不易自动计量物品如：薯片、馍皮、锅巴、果冻、茶叶、水饺、汤圆等。  
Applications: Suitable for fragile goods and those goods which are hard on auto metering, such as potato chips, steam bread chips, crispy rice, fruit jelly, boiled dumpling, rice dumpling etc.

### 技术规格Specifications

型号 Model	SK-L520
最大包薄膜宽度 Packing Film Width	Max. 520mm
制袋长度 Bag Length	80-350mm
制袋宽度 Bag Width	80-250mm
包装容积	2000ml
包装速度 Packing Speed	5-55bags/min
薄膜厚度 Packing Film Thickness	0.04-0.08mm
电源类型及功率 Power Supply	220V, 3kw
外形尺寸 Machine Size	(L)1430x(W)1200x(H)1700mm
机器总重量 Machine Net Weight	650kg



## SK-L620/L720立式全自动包装机

SK-L620/L720 Vertical Automatic Packaging Machine



### 主要结构和性能特点Features

- 1.采用彩色中英文触摸屏和进口PLC控制，操作方便、直观高效。
  - 2.气路控制和电路控制独立分离，噪音小，电路更稳定。
  - 3.采用真空双皮带伺服电机拉膜；拉膜阻力小，实现高精度定位，尺寸准确，包装袋成型好，更美观，皮带不易磨损。
  - 4.采用外置式放膜机构，包装膜安装更简单、更容易。
  - 5.本机与计量装置相配套，自动完成送料、计量、充填制袋、打印日期、充气（排气）、成品输送的全过程。
1. Imported PLC and color touch screen, human-machine interface, easy operation, intuitionistic and efficient.
  2. Separate pneumatic control and power control, noise is low, and the circuit is more stable.
  3. Vacuum film feeding device and two synchronous belt device with servo control system, less film pulling resistance, high orientation precision, bag design can be kept well. And belts are more durable.
  4. External film feeding mechanism. Film setting is easier and faster.
  5. Works with metering device, it can complete the whole procedure of metering, filling, bagging, date printing, exhausting, counting-automatically.

### 适用范围Applications

选配不同的计量装置，可包装各种不同种类的包装。  
Suitable for packing different kinds of product with different metering devices.



### 可适合的配套 Optional devices



1.电脑组合称  
Electronic Weighing System



2.量杯计量机  
Volumetric Cup Metering Device



3.半自动投料输送机  
Semi-automatic Feeding Device

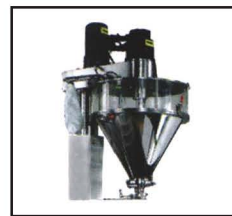

4.螺旋式计量机  
Auger Filler



5.液体罐装计量机  
Liquid Filling and Weighing Device

### 技术规格Specifications

型号 Model	SK-L620	SK-L720
耗气量 Air Consumption	0.65Mpa, 4M <sup>3</sup> /min, 6kg/cm <sup>2</sup>	0.65Mpa, 4M <sup>3</sup> /min, 6kg/cm <sup>2</sup>
包装薄膜宽度 Packing Film Width	Max 620mm	Max 720mm
制袋长度 Bag Length	100-400mm	100-500mm
制袋宽度 Bag Width	150-300mm	180-350mm
卷材最大外径 Packing Film Roll Diameter	Max. 360mm	Max. 360mm
包装速度 Packing Speed	5-55bags/min	5-55bags/min
包装薄膜厚度 Packing Film Thickness	0.04-0.08mm	0.04-0.08mm
电源规格 Power Supply	220V, 50/60Hz, 3Kw	220V, 50/60Hz, 3Kw
机器尺寸 Machine Size	(L)1780x (W)1300 x(H)1950	(L)1800x (W)1310 x(H)2050
机器净重 Machine Net Weight	700kg	750kg

## SK-L620F/L720F螺杆计量自动包装体系

SK-L620F/L720F Vertical Form-Fill-Seal Machine for Powder



### 主要结构和性能特点 Features

- 1.螺杆计量装置为SS304开启式料仓，日常清理，维修方便。
  - 2.伺服控制计量系统实现精度高，计量快，噪音低等优点。
  - 3.本机可从制袋，计量，充填，封合，打码到切袋一次性自动完成。
1. Open type SS304 auger filler, easy for daily cleaning and convenience for maintenance.
  2. Servo control system, fast metering, high accuracy and low noise.
  3. This machine completes the whole packing procedure of measuring, loading materials, bagging, date printing, exhausting and products transporting automatically as well as counting.

### 适用范围Applications

适用于奶粉、豆奶粉、咖啡粉、淀粉、面粉等产品的包装。  
Suitable for packing milk powder, soy milk powder, coffee powder, starch and flour etc.

### 本套机组Complete set of this machine

- 1.SK-L620、SK-L720 主机 SK-L620/SK-L720 basic packer
- 2.螺旋计量机 Auger filler
- 3.螺旋送料机 Screw conveyor
- 4.成品输送机 Finished product conveyor

## SK-L620DT/L720DT组合称量全自动包装体系

SK-L620DT/L720DT Combined Weighing Full Automatic Packaging System



### 主要结构和性能特点Features

- 1.采用电子称量方式，包装重量更精确，生产成本更低廉。
  - 2.中英文触摸屏显示，操作直观、简单。
  - 3.进口PLC电脑控制系统，运行更稳定，可不停机调整任何参数。
  - 4.采用伺服电机拉膜，定位更准确。
  - 5.包装的款式多样化，背封、插角、连袋、冲孔等。
  - 6.生产制袋、封口、包装、打印日期一次性完成。
1. Electronic measuring way, weighing is more accuracy and lower production cost.
  2. Touch screen displays in Chinese and English. Easy operation, intuitionistic and efficient.
  3. Imported PLC computer control system, running more stable, and parameters can be adjusted without stopping the machine.
  4. Servo film transporting system for accurate positioning, ensure to show the whole bag design.
  5. Different kinds of bag shape are available according customers' request.
  6. It can finished all processes from feeding, measuring, filling, date printing, air exhaust, finished product transferring and counting automatically.

### 适用范围Applications

适合包装颗粒、块状、条状，如饼干、锅巴、花生、瓜子、蚕豆、薯片、虾条等。  
Suitable for packing granules, pieces and strips products, such as biscuits, crispy rice, peanuts, melon seeds, broad beans, potato chips and prawn crackers etc.

### 本套机组Complete set of this machine

- 1.SK-L620、SK-L720 主机 SK-L620/SK-L720 basic packer
- 2.十头电子称 Ten head combined scale
- 3.Z型上料机 Z type material conveyor
- 4.振动喂料机 Vibrating feeding machine
- 5.支撑平台 Supporting platform
- 6.成品输送机 Finished product conveyor



## SK-L520T/L620T 立式全自动盒式包装机

SK-L520T/L620T Vertical Automatic Box Packaging Machine



### 主要结构和性能特点Features

- 1.采用触摸屏和稳定可靠的PLC控制，制袋、计量、充填、封合、打码、切袋一次性完成。
- 2.盒式包装袋成型，更美观。
- 3.拉膜采用伺服电机控制，实现高精度定位，尺寸准确。
- 4.采用外置式放膜机构，包装膜安装更容易。
- 5.纵封封合过程；自动调整偏差量，极大降低劳动强度。
- 6.制袋形式折角烫边，新颖高档，是当今世界主流袋形。

### 适用范围Applications

适合于膨化食品，虾条，花生，爆米花，麦片，瓜子，果冻，白糖，食盐，洗衣粉等颗粒状条，短条状，粉条物料的包装。



620成型器衣领 620真空拉膜封口

### 可适合的配套 Optional devices



1.电脑组称  
Electronic Weighing System



半自动投料输送机  
Semi-automatic Feeding Device



2.量杯计量机  
Volumetric Cup Metering Device

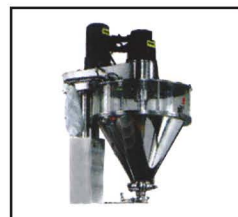

4.螺旋式计量机  
Auger Filler



5.液体罐装计量机  
Liquid Filling and Weighing Device

### 技术规格Specifications

型号Model	SK-L520T	SK-L620T
制袋正面中间宽度 Middle Width of Front Bag	75-160(mm)	90-190(mm)
制袋侧面中间宽度Middle Width of By Side Bag	40-80(mm)	50-120(mm)
烫边宽度 Ironing Width	5-10(mm)	5-10(mm)
制袋长度 Bag Length	100-350(mm)	100-400(mm)
包装速度 Packing Speed	5-55(bags/min)	5-55(bags/min)
包装膜材料 Film Material	OPP/CPP OPP/CE PE/PET	OPP/CPP OPP/CE PE/PET
包装膜宽度 Film Width	300-520mm	350-620mm
电源参数 Power	220v,50/60Hz,5.5kw	220v,50/60Hz,5.5kw



## SK-G300固体物料计量包装生产线 (给袋式包装机)

SK-G300 Solid metering and packaging production line



粉剂计量包装生产线  
Powder metering and packaging production line



液体、浆体计量包装生产线  
Liquid & thick liquid metering and packaging production line

### 主要结构和性能特点Features

- 1.包装适用范围广泛，对于多层复合膜制成的预约袋、纸袋均可应用，包材损耗低，封口质量好。
- 2.快速更换包装规格，自动给袋装备的宽度可通过调节手柄轻松快捷调整。
- 3.机器标配检测装置，可以检测机器在没有包装机或包装袋没有打开的情况下使充填装备不进行充填，热封口装置不封口，从而避免浪费包材和原料。
- 4.变频调速，本机使用变频调速装置，生产中可根据实际需要在一定的范围内随意调节。
- 5.采用先进的PLC加POD（触摸屏）电气控制系统，操作简单，易学。

### Features:

- 1.Extensive packing bag range,suitable for multilayer compound plastic prefabrication bag and paper bag,low loss and good sealing quality.
- 2.Quick and easy to change packing size,the width of automatic given bag device is easy to adjust by handle.
- 3.Standard with check device,which can check when there is without packing machine or packing bag is not open,the filling device and sealing device do not work to avoid wasting packing bags and material.
- 4.Frequency Control System,packing speed can be adjusted within the range according to the actual situation.
- 5.Adopts PLC with touch screen control system,the man-machine interface,easy to learn and operate.

### 技术规格Specifications

机型Type	固体物料专用 Specialized for solid	液体、浆体专用 Specialized for liquid and thick liquid	粉剂专用 Specialized for powder
包装袋类型 Pouch type	自立袋、手提袋、四边封袋、三边封袋、纸袋等复合袋Portable bag, Stand bag, Zipper bag, Edging bag 4 sides, Edging bag 3 sides, Paper bag Pouch with cap etc.		
包装袋尺寸Size of bag	W:100-200mm L:100-300mm		
充填范围Fining scope	5-1500g		
包装速度Speed	25-45包/分 (其速度有产品自身及充填重量决定) Speed 25-45bags/min(The speed depends on the product status and filling weight)		
包装精度 Package accuracy Total power	偏差 ≤ ±1 error ≤ ±1		
总功率powder	5KW	1.5KW	3.6KW





## SK-L420M/L520M中型煤炭自动包装机(特殊机型)

Sk-L420M /L520M middle-sized coal automatic vertical packaging machine



### 适用范围: Applications

煤块、石灰块、煤粒、石灰粒、矿粉、石灰粉等颗粒粉状的包装。  
Applications: Suitable for packing pieces of coal or lime; granular of coal or lime, mineral powder, lime powder and other similar small grain products.



机箱内部密封  
Seal up inside



机箱内吸尘部份  
Dust Absorption Device



横封出口部份  
horizontal sealing exit



机身后部部份  
Machine back Side



机身侧面  
machine side

### 主要结构和性能特点: Features

1. 采用彩色中英文触摸屏和进口PLC控制、制袋、充填、封合、切袋一次性完成。
2. 气路控制和电路控制独立分离，噪音小，电路更稳定。
3. 采用双皮带伺服电机拉膜：拉膜阻力小，包装袋成型好，更美观，皮带不易磨损。
4. 采用伺服控制，实现高精度定位，尺寸准确。
5. 内至放膜，包装膜不易被尘灰污染。
6. 整机采用封闭式机构，有效防止粉尘进入机器内部。
7. 过膜处彩用吸尘机构使包装膜更加清洁走膜更顺畅。
8. 机箱各连接处采用密封胶以及各种防尘技术使机箱内尽可能的减少粉尘，保证机械正常运行。

### 技术规格: Specifications

机器 type	SK-L420M	SK-L520M
最大包薄膜宽度 Max. Film width	Max. 420mm	Max. 520mm
耗气量 Air Consumption	0.65Mpa, 3m <sup>3</sup> /min. 6kg/cm <sup>2</sup>	0.65Mpa, 4m <sup>3</sup> /min. 6kg/cm <sup>2</sup>
制袋长度 Bag length	80-300mm	80-350mm
制袋宽度 Bag width	80-200mm	100-250mm
包装容积 Packaging cubage	1000ml	2000ml
包装速度 Packaging speed	5-65bags/min	5-60bags/min
薄膜厚度 Packing thickness	0.04-0.08mm	0.04-0.08mm
电源类型及功率 Power	220V, 50/60HZ, 3kw	220V, 50/60HZ, 3kw
外形尺寸 Dimension	(L)1540x(W)930x(H)1700	(L)1430x(W)1050x(H)1800
机器总重量 Total weight of machine	450kg	650kg

1. Imported PLC and color touch screen, human-machine interface, easy operation, intuitionistic and efficient.
2. Separate pneumatic control and power control, noise is low, and circuit is more stable.
3. Adopts two synchronous belts film pulling device with servo control system, less film pulling resistance, high orientation precision, bag design can be kept well. And belts is more durable.
4. Servo control, high-precision positioning, accurate size.
5. Inside film feeding mechanism. Film can not be easily pollution.
6. Close down type mechanism, defending dust into inside of machine.
7. Collecting dust mechanism for film transferring, packing film can be keep clean and transfer smoothly.
8. Each connection of machine frame use a seal to avoid the dust into the chassis to make sure the machine can run normally.

## 水平皮带集中输送包装解决方案

Horizontal Belt Type Conveying and Packing Solution

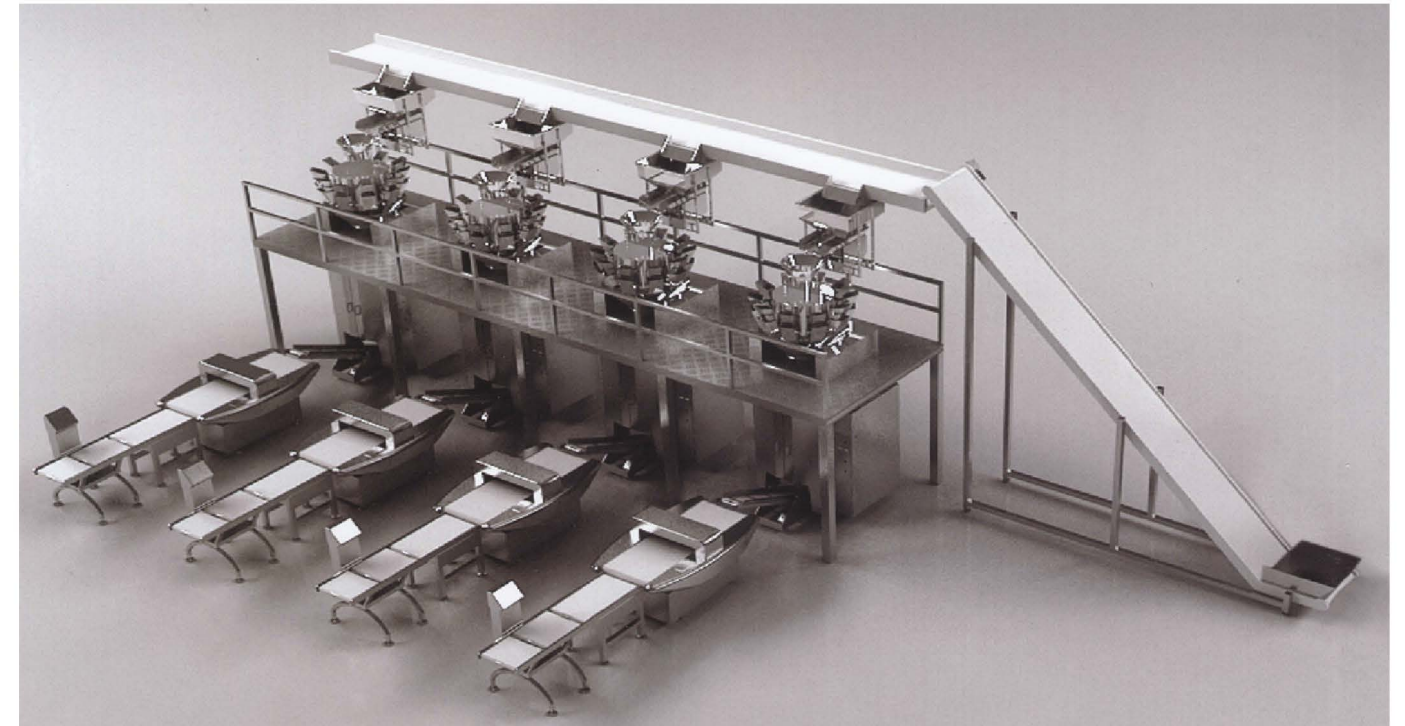

### 全自动罐装解决方案

Full Automatic Filling Solution

### 特别优势:

1. 此集中供料方案适用于膨化食品的包装。整套结构紧凑，占地小。
2. 集中供料节约设备购机维修成本、人力操作成本。
3. 皮带水平输送物料，结构简单、成本低、经济、优惠是其最大的特点。

### 主要结构和性能特点 Features

1. 采用彩色触摸屏式人机界面操作。
  2. 数字化操作和PLG控制系统，易学易操作。
  3. 可根据需要分切、投放物的规格进行简单设定，使分切、投放物控制在最佳状态。
1. Adopt colorful touch screen, human-machine interface.
  2. Digital operation and PLC control system, easy to learn and control.
  3. Easy to set parameter according to cut and pouch feeding size.

### 适用范围 Applications

本机可实现脱氧剂、保鲜剂、干燥剂、调味品等连续片状包装物的自动分切和投放功能。  
Automatically cutting and dispensing for continuous bags of deoxidant, antistaling agent, silica gel, and flavor etc

### 技术规格 Specifications

规格类型 Item	SK-801	机器外形尺寸 Dimension:	600 x 750 x 1500MM
投放速度 Feeding Speed	20-160bag/min	机器噪声 Db	≤ 20 dB
料包宽度 Bag Width	15-60mm	切刀可切厚度 Cutting Workable Thickness	≤ 1MM
料包厚度 Bag Thickness	3-12mm	电源类型 Voltage	220V 50Hz
总功率 Power	0.35KW	料包材料 Packing Material	塑料、铝箔、类纸质等。
机器净重 Machine N.W.	55kg	料包规格 Bag Size	内孔 ≥ φ25 外径 ≤ φ270

### Full Automatic Filling Solution

1. This centralized feeding scheme is suitable for puffed food packaging. It is a complete set of compact structure and economic space occupation.
2. Centralized feeding can save the cost of equipment procurement, maintenance, and human operating.
3. Horizontal belt conveying material, simple structure, low cost, economy, preferential. It is the biggest characteristic.

## SK-801自动投包机 SK-801 Automatic Pouch Dispenser





### SK-L160A颗粒立式自动包装机

SK-L160A Granule Vertical Automatic Packaging Machine



#### 主要结构和性能特点: Features

1. 整机结构紧凑, 牢固, 设计合理, 简洁。
2. 采用光电眼控制系统, 步进电机拉膜, 可靠, 性能稳定, 噪音低。
3. 采用变频调速, 运作更稳定, 噪音更低, 故障率低。
4. 全自动从计量, 充填制袋, 日期打印到产品输出一次性完成。
5. 借用弹簧压刀原理, 气动分切, 五连包更加稳定。

#### 适用范围: Applications

适合于膨化食品, 虾条, 花生, 瓜子, 大米, 种子, 味精, 玉米花等颗粒状, 条片状, 固物料的包装。  
Suitable for packing puffed food, shrimp strip, peanut, cooked seeds, rice, seed, monosodium glutamate, popcorn and other grain, strip and flake shaped solid material.



### SK-L160B 链斗式半自动包装机

SK-L160B Bucket Chain Semi-Automatic Packaging Machine



#### 主要结构和性能特点: Features

1. 人工计量投料。
  2. 链斗式输送方便投放或多种物料包装。
- Function and structure characteristics:  
1 Artificially measuring feeding  
2 Chain conveyor convenient on different material or packaging.

#### 适用范围: Applications

适合于易碎物料: 薯片, 锅巴, 苹果片, 果冻等。  
Suitable for packing fragile material:  
potato chips, crispy rice, apple flakes, fruit jelly



### SK-L160F粉剂包装机

SK-L160F Powder Automatic Packaging Machine



#### 主要结构和性能特点: Features

1. 整机结构紧凑, 牢固, 设计合理, 简洁。
  2. 螺旋计量, 步进电机驱动设计合理、可靠, 性能稳定。
  3. 速度快, 精度高, 噪音更低, 故障率低。
  4. 全自动从计量, 充填制袋, 日期打印到产品输出一次性完成。
1. The compact structure, firm, reasonable design, concise.  
2. Spiral measurement, stepping motor drive design is reasonable and reliable, stable performance.  
3. Fast speed, high precision, low noise and low failure rate.  
4. It can finished automatically from metering, filling, date printing to product output and counting.

#### 适用范围: Applications

适合不粘, 如流动性好的粉末, 豆粉, 面粉, 胡椒粉, 饲料粉, 奶粉、咖啡粉等粉状类物料的包装。  
Suitable for packing non-sticky and with flow property powdery goods, such as soybean meal, flour, starch, milk powder, pepper, chilli powder, starch, feed, coffee powder, washing powder, wheat powder, maize powder, paprika etc.



### SK-L160SF粉剂三边封包装机

SK-L160SF Powder Automatic Packaging Machine



#### 主要结构和性能特点: Features

1. 整机结构紧凑, 牢固, 设计合理, 简洁。
  2. 螺旋计量, 步进电机驱动设计合理、可靠, 性能稳定。
  3. 速度快, 精度高, 噪音更低, 故障率低。
  4. 全自动从计量, 充填制袋, 日期打印到产品输出一次性完成。
1. The compact structure, firm, reasonable design, concise.  
2. Spiral measurement, stepping motor drive design is reasonable and reliable, stable performance.  
3. Fast speed, high precision, low noise and low failure rate.  
4. It can finished automatically from metering, filling, date printing to product output and counting.

#### 适用范围: Applications

适合不粘, 如流动性好的粉末, 豆粉, 面粉, 胡椒粉, 饲料粉, 奶粉、咖啡粉等粉状类物料的包装。  
Suitable for packing non-sticky and with flow property powdery goods, such as soybean meal, flour, starch, milk powder, pepper, chilli powder, starch, feed, coffee powder, washing powder, wheat powder, maize powder, paprika etc.



### SK-L160AB颗粒立式自动包装机

SK-L160AB Granule Vertical Automatic Packaging Machine



#### 主要结构和性能特点: Features

1. 整机结构紧凑, 牢固, 设计合理, 简洁。
  2. 采用光电眼控制系统, 步进电机拉膜, 可靠, 性能稳定, 噪音低。
  3. 可以转盘自动计量下料, 也可以人工投料, 可以在产品中投奖卡及加其他产品入袋子
  4. 全自动从计量, 充填制袋, 日期打印到产品输出一次性完成
1. The machine is featured with compact structure, durable, logical design and precise.  
2. Adopts light sensor control system, stepping motor control film transporting system, reliable, and stable performance.  
3. It can be turntable automatic metering blanking, artificial feeding, can throw cards and other products into the bag  
4. It can finish automatically all processes, such as measuring, filling and bag marking.

#### 适用范围: Applications

适合于膨化食品, 虾条, 瓜子, 大米, 种子, 薯片, 锅巴, 果冻, 配件, 速冻食品等颗粒状, 条片状的包装。  
Suitable for packing puffed food, shrimp, melon seeds, rice, seeds, potato chips, crispy rice, jelly, accessories, frozen food and other granular or sheet type.



### SK-L160YS自动包装机

SK-L160YS Automatic Vertical Packaging Machine



#### 主要结构和性能特点: Features

1. 采用变频调速, 运作更稳定, 噪音更低, 故障率低。
  2. 全气动控制, 灌装精度高, 操作简单, 拆装清洗方便。
  3. 全自动从计量, 充填制袋, 日期打印到产品输出一次性完成。
1. Adopts light sensor control system, stepping motor control film transporting system, reliable, and stable performance.  
2. Pneumatic control, high accurate metering, easy to operate and convenience for daily cleaning.  
3. It can finish automatically all processes, such as measuring, filling and bag marking.

#### 适用范围: Applications

适用于食品, 医药, 化工产品中的液体物料的自动包装, 如: 洗发水, 沐浴露, 面霜, 调味精, 果汁, 水等。  
Suitable for packing nonviscous liquid, such as shampoo, shower gel, skin lotion, tooth paste, cosmetic cream, fruit juice, water etc.



### SK-L120SY液体自动包装机

SK-L120SY three side sealing vertical packaging machine



#### 主要结构和性能特点: Features

1. 采用变频调速, 运作更稳定, 噪音更低, 故障率低。
  2. 全气动控制, 灌装精度高, 操作简单, 拆装清洗方便。
  3. 全自动从计量, 充填制袋, 日期打印到产品输出一次性完成。
1. Adopts light sensor control system, stepping motor control film transporting system, reliable, and stable performance.  
2. Pneumatic control, high accurate metering, easy to operate and convenience for daily cleaning.  
3. It can finish automatically all processes, such as measuring, filling and bag marking.

#### 适用范围: Applications

适用于食品, 医药, 化工产品中的液体物料的自动包装, 如: 洗发水, 沐浴露, 面霜, 调味精, 果汁, 水等。  
Suitable for packing nonviscous liquid, such as shampoo, shower gel, skin lotion, tooth paste, cosmetic cream, fruit juice, water etc.



### SK-L140K立式自动包装机

SK-L140K Vertical Automatic Packaging Machine



#### 主要结构和性能特点: Features

1. 整机结构紧凑, 牢固, 设计合理, 简洁。
  2. 采用光电眼控制系统, 步进电机拉膜, 可靠, 性能稳定, 噪音低。
  3. 采用变频调速, 运作更稳定, 噪音更低, 故障率低。
  4. 全自动从计量, 充填制袋, 日期打印到产品输出一次性完成。
  5. 借用弹簧压刀原理, 气动分切, 五连包更加稳定。
1. The machine is featured with compact structure, durable, logical design and precise.  
2. Adopts light sensor control system, stepping motor control film transporting system, reliable, and stable performance.  
3. Using VVVF, operation is much more stable, low noise and low malfunction.  
4. It can finish automatically all processes, such as measuring, filling and bag marking.  
5. With spring pressure knife principle, pneumatic cutting, 5 linking bags is more stable.

#### 适用范围: Applications

适合于膨化食品, 虾条, 花生, 瓜子, 大米, 种子, 味精, 玉米花等颗粒状, 条片状, 固物料的包装。  
Suitable for packing puffed food, shrimp strip, peanut, cooked seeds, rice, seed, monosodium glutamate, popcorn and other grain, strip and flake shaped solid material.



#### 技术规格: Specifications

机器型号 Model	SK-L160A颗粒立式自动包装机	SK-L160B链斗式半自动包装机	SK-L160AB颗粒立式自动包装机	SK-L160YS自动包装机
卷膜宽度 Film Width	80-320mm	80-320mm	80-320mm	80-320mm
制袋长度 Bag Length	50-200mm	50-200mm	50-200mm	50-200mm
制袋宽度 Bag Width	30-150mm	30-150mm	30-150mm	40-150mm
计量范围 Metering Range	50-500ml	20-150mm	50-150mm	10-250ml
包装速度 Packing Speed	30-90bas/min	30-80bag/min	30-80bag/min	15-65bags/min
卷材外径 Film Roll Diameter	Max. 300mm	Max. 300mm	Max. 300mm	Max. 300mm
包装膜厚度 Packing Film Thickness	0.04-0.08mm	0.05-0.08mm	0.05-0.08mm	0.04-0.08mm
使用电源规格 Power Supply	220V50Hz 2kw	220V50Hz 2.2kw	220V50Hz 2.2kw	220V50Hz 2kw
机器重量 Machine Net Weight	350kg	350kg	350kg	350kg
包装材料 Packing Film Material	OPP/CPP OPP/CE MST/PE/PET/PE	OPP/CPP OPP/CE MST/PE/PET/PE	OPP/CPP OPP/CE MST/PE/PET/PE	OPP/CPP OPP/CE MST/PE/PET/PE
机械尺寸 Machine Size	(L)1000*(W)840*(H)1900	(L)2080*(W)700*(H)1600	(L)2080*(W)700*(H)2150	(L)880*(W)880*(H)1620

#### 技术规格: Specifications

机器型号 Machine model	SK-L160F粉剂包装机	SK-L160SF粉剂三边封包装机	SK-L120SY液体自动包装机	SK-L140K立式自动包装机
卷膜宽度 Packaging Film Width	320mm	280mm	240mm	260mm
制袋长度 Bag Length	50-200mm	50-200mm	50-200mm	50-140mm
制袋宽度 Bag Width	30-150mm	50-140mm	30-110mm	30-120mm
计量范围 Metering Range	30-300ml	30-150ml	30-150ml	10-100ml
包装速度 Packing Speed	20-65bags/min	15-65bags/min	15-65bags/min	50-148bas/min
卷材外径 Packing Film Roll Diameter Max.	Max. 300mm	Max. 300mm	Max. 300mm	Max. 300mm
包装膜厚度 Packing Film Thickness	0.04-0.08mm	0.04-0.08mm	0.04-0.08mm	0.04-0.08mm
使用电源规格 Power Supply	220V50Hz 2.4Kw	220V50Hz 2.2Kw	220V50Hz 2Kw	220V50Hz 2.4kw
机器重量 Machine Net Weight	350kg	350kg	350kg	300kg
包装材料 Packing Film Material	OPP/CPP OPP/CE MST/PE/PET/PE	OPP/CPP OPP/CE MST/PE/PET/PE	OPP/CPP OPP/CE MST/PE/PET/PE	OPP/CPP OPP/CE MST/PE/PET/PE
机械尺寸 Machine Size	(L)1050*(W)920*(H)1610	(L)1000*(W)910*(H)1620	(L)1120*(W)810*(H)1720	(L)850*(W)670*(H)1620



### SK-L160A颗粒立式自动包装机

SK-L160A Granule Vertical Automatic Packaging Machine



#### 主要结构和性能特点: Features

1. 整机结构紧凑, 牢固, 设计合理, 简洁。
2. 采用光电眼控制系统, 步进电机拉膜, 可靠, 性能稳定, 噪音低。
3. 采用变频调速, 运作更稳定, 噪音更低, 故障率低。
4. 全自动从计量, 充填制袋, 日期打印到产品输出一次性完成。
5. 借用弹簧压刀原理, 气动分切, 五连包更加稳定。

#### 适用范围: Applications

适合于膨化食品, 虾条, 花生, 瓜子, 大米, 种子, 味精, 玉米花等颗粒状, 条片状, 固物料的包装。  
Suitable for packing puffed food, shrimp strip, peanut, cooked seeds, rice, seed, monosodium glutamate, popcorn and other grain, strip and flake shaped solid material.



### SK-L160B 链斗式半自动包装机

SK-L160B Bucket Chain Semi-Automatic Packaging Machine



#### 主要结构和性能特点: Features

1. 人工计量投料。
2. 链斗式输送方便投放或多种物料包装。

Function and structure characteristics:

- 1 Artificially measuring feeding
- 2 Chain conveyor convenient on different material or packaging.

#### 适用范围: Applications

适合于易碎物料: 薯片, 锅巴, 苹果片, 果冻等。

Suitable for packing fragile material:

potato chips, crispy rice, apple flakes, fruit jelly



### SK-L160F粉剂包装机

SK-L160F Powder Automatic Packaging Machine



#### 主要结构和性能特点: Features

1. 整机结构紧凑, 牢固, 设计合理, 简洁。
2. 螺旋计量, 步进电机驱动设计合理、可靠, 性能稳定。
3. 速度快, 精度高, 噪音更低, 故障率低。
4. 全自动从计量, 充填制袋, 日期打印到产品输出一次性完成。

1. The compact structure, firm, reasonable design, concise.
2. Spiral measurement, stepping motor drive design is reasonable and reliable, stable performance.
3. Fast speed, high precision, low noise and low failure rate.
4. It can finished automatically from metering, filling, date printing to product output and counting.

#### 适用范围: Applications

适合不粘, 如流动性好的粉末, 豆粉, 面粉, 胡椒粉, 饲料粉, 奶粉、咖啡粉等粉状类物料的包装。  
Suitable for packing non-sticky and with flow property powdery goods, such as soybean meal, flour, starch, milk powder, pepper, chilli powder, starch, feed, coffee powder, washing powder, wheat powder, maize powder, paprika etc.

### SK-L160SF粉剂三边封包装机

SK-L160SF Powder Automatic Packaging Machine



#### 主要结构和性能特点: Features

1. 整机结构紧凑, 牢固, 设计合理, 简洁。
2. 螺旋计量, 步进电机驱动设计合理、可靠, 性能稳定。
3. 速度快, 精度高, 噪音更低, 故障率低。
4. 全自动从计量, 充填制袋, 日期打印到产品输出一次性完成。

1. The compact structure, firm, reasonable design, concise.
2. Spiral measurement, stepping motor drive design is reasonable and reliable, stable performance.
3. Fast speed, high precision, low noise and low failure rate.
4. It can finished automatically from metering, filling, date printing to product output and counting.

#### 适用范围: Applications

适合不粘, 如流动性好的粉末, 豆粉, 面粉, 胡椒粉, 饲料粉, 奶粉、咖啡粉等粉状类物料的包装。  
Suitable for packing non-sticky and with flow property powdery goods, such as soybean meal, flour, starch, milk powder, pepper, chilli powder, starch, feed, coffee powder, washing powder, wheat powder, maize powder, paprika etc.



### SK-L160AB颗粒立式自动包装机

SK-L160AB Granule Vertical Automatic Packaging Machine



#### 主要结构和性能特点: Features

1. 整机结构紧凑, 牢固, 设计合理, 简洁。
2. 采用光电眼控制系统, 步进电机拉膜, 可靠, 性能稳定, 噪音低。
3. 可以转盘自动计量下料, 也可以人工投料, 可以在产品中投奖卡及加其他产品入袋子
4. 全自动从计量, 充填制袋, 日期打印到产品输出一次性完成

1. The machine is featured with compact structure, durable, logical design and precise.
2. Adopts light sensor control system, stepping motor control film transporting system, reliable, and stable performance.
3. It can be turntable automatic metering blanking, artificial feeding, can throw cards and other products into the bag
4. It can finish automatically all processes, such as measuring, filling and bag marking.

#### 适用范围: Applications

适合于膨化食品, 虾条, 瓜子, 大米, 种子, 薯片, 锅巴, 果冻, 配件, 速冻食品等颗粒状, 条片状的包装。  
Suitable for packing puffed food, shrimp, melon seeds, rice, seeds, potato chips, crispy rice, jelly, accessories, frozen food and other granular or sheet type.



### SK-L160YS自动包装机

SK-L160YS Automatic Vertical Packaging Machine



#### 主要结构和性能特点: Features

1. 采用变频调速, 运作更稳定, 噪音更低, 故障率低。
2. 全气动控制, 灌装精度高, 操作简单, 拆装清洗方便。
3. 全自动从计量, 充填制袋, 日期打印到产品输出一次性完成。

1. Adopts light sensor control system, stepping motor control film transporting system, reliable, and stable performance.
2. Pneumatic control, high accurate metering, easy to operate and convenience for daily cleaning.
3. It can finish automatically all processes, such as measuring, filling and bag marking.

#### 适用范围: Applications

适用于食品, 医药, 化工产品中的液体物料的自动包装, 如: 洗发水, 沐浴露, 面霜, 调味精, 果汁, 水等。  
Suitable for packing nonviscous liquid, such as shampoo, shower gel, skin lotion, tooth paste, cosmetic cream, fruit juice, water etc.



### SK-L120SY液体自动包装机

SK-L120SY three side sealing vertical packaging machine



#### 主要结构和性能特点: Features

1. 采用变频调速, 运作更稳定, 噪音更低, 故障率低。
2. 全气动控制, 灌装精度高, 操作简单, 拆装清洗方便。
3. 全自动从计量, 充填制袋, 日期打印到产品输出一次性完成。

1. Adopts light sensor control system, stepping motor control film transporting system, reliable, and stable performance.
2. Pneumatic control, high accurate metering, easy to operate and convenience for daily cleaning.
3. It can finish automatically all processes, such as measuring, filling and bag marking.

#### 适用范围: Applications

适用于食品, 医药, 化工产品中的液体物料的自动包装, 如: 洗发水, 沐浴露, 面霜, 调味精, 果汁, 水等。  
Suitable for packing nonviscous liquid, such as shampoo, shower gel, skin lotion, tooth paste, cosmetic cream, fruit juice, water etc.



### SK-L140K立式自动包装机

SK-L140K Vertical Automatic Packaging Machine



#### 主要结构和性能特点: Features

1. 整机结构紧凑, 牢固, 设计合理, 简洁。
2. 采用光电眼控制系统, 步进电机拉膜, 可靠, 性能稳定, 噪音低。
3. 采用变频调速, 运作更稳定, 噪音更低, 故障率低。
4. 全自动从计量, 充填制袋, 日期打印到产品输出一次性完成。
5. 借用弹簧压刀原理, 气动分切, 五连包更加稳定。

1. The machine is featured with compact structure, durable, logical design and precise.
2. Adopts light sensor control system, stepping motor control film transporting system, reliable, and stable performance.
3. Using VVVF, operation is much more stable, low noise and low malfunction.
4. It can finish automatically all processes, such as measuring, filling and bag marking.
5. With spring pressure knife principle, pneumatic cutting, 5 linking bags is more stable.

#### 适用范围: Applications

适合于膨化食品, 虾条, 花生, 瓜子, 大米, 种子, 味精, 玉米花等颗粒状, 条片状, 固物料的包装。  
Suitable for packing puffed food, shrimp strip, peanut, cooked seeds, rice, seed, monosodium glutamate, popcorn and other grain, strip and flake shaped solid material.



#### 技术规格: Specifications

机器型号 Model	SK-L160A颗粒立式自动包装机	SK-L160B链斗式半自动包装机	SK-L160AB颗粒立式自动包装机	SK-L160YS自动包装机
卷膜宽度 Film Width	80-320mm	80-320mm	80-320mm	80-320mm
制袋长度 Bag Length	50-200mm	50-200mm	50-200mm	50-200mm
制袋宽度 Bag Width	30-150mm	30-150mm	30-150mm	40-150mm
计量范围 Metering Range	50-500ml	20-150mm	50-150mm	10-250ml
包装速度 Packing Speed	30-90bas/min	30-80bag/min	30-80bag/min	15-65bas/min
卷材外径 Film Roll Diameter	Max. 300mm	Max. 300mm	Max. 300mm	Max. 300mm
包装膜厚度 Packing Film Thickness	0.04-0.08mm	0.05-0.08mm	0.05-0.08mm	0.04-0.08mm
使用电源规格 Power Supply	220V50Hz 2kw	220V50Hz 2.2kw	220V50Hz 2.2kw	220V50Hz 2kw
机器重量 Machine Net Weight	350kg	350kg	350kg	350kg
包装材料 Packing Film Material	OPP/CPP OPP/CE MST/PE/PET/PE	OPP/CPP OPP/CE MST/PE/PET/PE	OPP/CPP OPP/CE MST/PE/PET/PE	OPP/CPP OPP/CE MST/PE/PET/PE
机械尺寸 Machine Size	(L)1000*(W)840*(H)1900	(L)2080*(W)700*(H)1600	(L)2080*(W)700*(H)2150	(L)880*(W)880*(H)1620

#### 技术规格: Specifications

机器型号 Machine model	SK-L160F粉剂包装机	SK-L160SF粉剂三边封包装机	SK-L120SY液体自动包装机	SK-L140K立式自动包装机
卷膜宽度 Packaging Film Width	320mm	280mm	240mm	260mm
制袋长度 Bag Length	50-200mm	50-200mm	50-200mm	50-140mm
制袋宽度 Bag Width	30-150mm	50-140mm	30-110mm	30-120mm
计量范围 Metering Range	30-300ml	30-150ml	30-150ml	10-100ml
包装速度 Packing Speed	20-65bags/min	15-65bags/min	15-65bags/min	50-148bas/min
卷材外径 Packing Film Roll Diameter Max.	Max. 300mm	Max. 300mm	Max. 300mm	Max. 300mm
包装膜厚度 Packing Film Thickness	0.04-0.08mm	0.04-0.08mm	0.04-0.08mm	0.04-0.08mm
使用电源规格 Power Supply	220V50Hz 2.4Kw	220V50Hz 2.2Kw	220V50Hz 2Kw	220V50Hz 2.4kw
机器重量 Machine Net Weight	350kg	350kg	350kg	300kg
包装材料 Packing Film Material	OPP/CPP OPP/CE MST/PE/PET/PE	OPP/CPP OPP/CE MST/PE/PET/PE	OPP/CPP OPP/CE MST/PE/PET/PE	OPP/CPP OPP/CE MST/PE/PET/PE
机械尺寸 Machine Size	(L)1050*(W)920*(H)1610	(L)1000*(W)910*(H)1620	(L)1120*(W)810*(H)1720	(L)850*(W)670*(H)1620



## SK-L120S三角型全自动包装机

SK-L120S Full-automatic Triangle Bag Packaging Machine



### 主要结构和性能特点Features

采用光电眼控制系统，每包即可准确分切包装袋，成品形状呈三角型，款式新颖别致，独立料斗送料，可在一袋中包入多种物品。  
Using photo-sensor control system, each bag, can accurate slitting I triangle shape of finished product, Fashionable chic, independent, but in a hopper feed bag into the various items.

### 适用范围Applications

适合膨化食品、虾条、花生、爆米花、麦片、瓜子、炒货、果冻、白糖、盐、固体饮料等颗粒状、短条状、液体状食品的三角形包装。  
Suitable for packing puffed food, prawn cracker, peanut, popcorn, oatmeal, roasted seeds, jelly, white sugar, salt, instant granular drink and other granular, flake and liquid food in a triangle shape bag.



## SK-L200S三角形全自动包装机

SK-L200S Triangle Bag Automatic Packaging Machine



### 主要结构和性能特点Features

- 1.本机结构紧凑，牢固，操作简单，维护方便。
- 2.本机采用可编辑程序控制系统，超大触摸屏，直观，易懂。
- 3.采用伺服运膜系统，定位准确，包装美观。
- 4.全自动从计量，充填，制袋，日期打印到产品输送一次完成。
- 5.成品形状呈三角型，款式新颖别致。

- 1, The machine is featured with compact structure, durable, logical design and precise.
- 2, Adopts light sensor control system, stepping motor control film transporting system, reliable, and stable performance.
- 3, Using VVVF, operation is much more stable, low noise and low malfunction.
- 4, It can finish automatically all processes, such as measuring, filling and bag marking.
- 5, Triangle shape bag is more stylish,

### 适用范围Applications

适合于膨化食品，花生，瓜子，糖果，干果，种子，小饼干，砂糖，味精，茶叶等颗粒物品的三角形包装。  
Suitable for packing puffed grainy food such as peanuts, cooked seeds, candy, nuts, seeds, cookies, granulated sugar, tea, etc.,

### 技术规格Specifications

机器型号 Model	SK-L120S三角型全自动包装机	SK-L200S中型立式自动包装机
卷膜宽度 Packaging Film Width	Max 200mm	Max 220mm
制袋长度 Bag Length	30-200mm	30-200mm
制袋宽度 Bag Width	40-90mm	40-100mm
包装速度 Packing Speed	30-70bags/min	5-70bags/min
卷材外径 Packing Film Roll Diameter Max.	Max. 300mm	Max. 300
包装膜厚度 Packing Film Thickness	0.04-0.07mm	0.04-0.08mm
使用电源规格 Power Supply	220V50Hz, 2.4Kw	60Hz, 2.4KVA
机器重量 Machine Net Weight	300kg	400kg
包装材料 Packing Film Material	OPP/CPP, OPP/CE, MST/PE/PET/PE	OPP/CPP, OPP/PE, BOPP/VMPET/PE
机械尺寸 Machine Size	(L)1120*(W)810*(H)1720	(L)880*(W)810*(H)1350

## SK-LJD160A颗粒立式自动包装机

SK-LJD160A Granule vertical automatic packaging machine

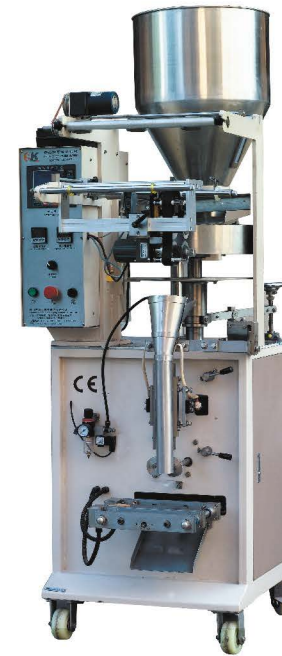

### 主要结构和性能特点Features

- 1.整机结构紧凑，牢固，设计合理，简洁。
- 2.采用光电眼控制系统，步进电机拉膜，可靠，性能稳定，噪音低。
- 3.采用变频调速，运作更稳定，噪音更低，故障率低。
- 4.全自动从计量，充填制袋，日期打印到产品输出一次性完成。
- 5.借用弹簧压刀原理，气动分切，五连包更加稳定。

- 1, The machine is featured with compact structure, durable, logical design and precise.
- 2, Adopts light sensor control system, stepping motor control film transporting system, reliable, and stable performance.
- 3, Using VVVF, operation is much more stable, low noise and low malfunction.
- 4, It can finish automatically all processes, such as measuring, filling and bag marking.
- 5, With spring pressure knife principle, pneumatic cutting, 5 linking bags is more stable.

### 适用范围Applications

适合于膨化食品，虾条，花生，瓜子，大米，种子，味精，玉米花等颗粒状，条片状，固物料的包装。  
Suitable for packing puffed food, shrimp strip, peanut, cooked seeds, rice, seed, monosodium glutamate, popcorn and other grain, strip and flake shaped solid material.

## SK-L160FT粉剂包装机

SK-L160F Powder Automatic Packaging Machine



### 主要结构和性能特点Features

- 1.整机结构紧凑，牢固，设计合理，简洁。
- 2.横式螺旋计量，步进电机驱动设计合理、可靠，性能稳定。
- 3.速度快，精度搞，噪音更低，故障率低。
- 4.全自动从计量，充填制袋，日期打印到产品输出一次性完成。

1. The compact structure, firm, reasonable design, concise.
2. Spiral measurement, stepping motor drive design is reasonable and reliable, stable performance.
3. Fast speed, high precision, low noise and low failure rate.
4. It can finished automatically from metering, filling, date printing to product output and counting.

### 适用范围Applications

适合不粘，如流动性好的粉末，豆粉，面粉，胡椒粉，饲料粉，奶粉、咖啡粉等粉状类物料的包装。  
Suitable for packing non-sticky and with flow property powdery-goods, such as soybean flour, chili powder, feedstuff powder, milk powder, coffee powder, etc.

### 技术规格Specifications

机器型号 Model	SK-LJD160A颗粒立式自动包装机	SK-L160FT粉剂包装机
卷膜宽度 Film Width	120-360mm	320mm
制袋长度 Bag Length	50-250mm	50-200mm
制袋宽度 Bag Width	50-170mm	30-150mm
计量范围 Metering Range	50-600ml	30-300ml
包装速度 Packing Speed	30-80bags/min	20-65bags/min
卷材外径 Film Roll Diameter	Max. 300mm	Max. 300mm
包装膜厚度 Packing Film Thickness	0.04-0.08mm	0.04-0.08mm
使用电源规格 Power Supply	220V50/60Hz, 2.2kw	220V50Hz, 2.4Kw
机器重量 Machine Net Weight	380kg	350kg
机械尺寸 Machine Size	(L) 1100x (W) 750x (H) 2000	(L)1050* (W) 920* (H)1610
包装材料 Packing Film Material	OPP/CPP, OPP/CE, MST/PE/PET/PE	OPP/CPP, OPP/CE, MST/PE/PET/PE



## SK-W250回转式枕包机 (升级版)

SK-W250 Rotary pillow packaging machine(up graded)

### 适用范围Applications

适用于饼干、米通、雪饼、蛋黄派、巧克力、面包、方便面、月饼、药品、日用品、工业零件、纸盒或托盘等各类有规则物体的包装。

Packaging various kinds of regular objects like biscuits, pies, chocolates, bread, instant noodles, moon-cakes, drugs, daily appliances, industrial parts, paper boxes, plates, etc.



## SK-W320 回转式枕包机 (升级版)

SK-W320 Rotary pillow packaging machine(up graded)

### 适用范围Applications

适用于饼干、米通、雪饼、蛋黄派、巧克力、面包、方便面、月饼、药品、日用品、工业零件、纸盒或托盘等各类有规则物体的包装。

Packaging various kinds of regular objects like biscuits, pies, chocolates, bread, instant noodles, moon-cakes, drugs, daily appliances, industrial parts, paper boxes, plates, etc.



### 主要结构和性能特点Features

1. 双变频器控制，袋长即设即切，无需调节空走，一步到位，省时省膜。
2. 人机界面，参数设定方便快捷。
3. 故障自诊断功能，故障显示一目了然。
4. 高感度光电眼色标跟踪，数字化输入封切位置，使封切位置更加准确。
5. 温度独立PID控制，更好适合各种包装材质。
6. 定位停机功能，不粘刀，不浪费包膜。
7. 传动系统简洁，工作更可靠，维护保养更方便。
8. 所有的控制由软件实现，方便功能调整和技术升级，永不落后。

1. Dual transducers control and bag length can be let and cut in one step.
2. Interface are easy and quick to set and operate.
3. Failures can be self-diagnosed and displays clearly.
4. High sensitivity electrical eye traces and sealing position is input numerically for accuracy.
5. PID control temperature independently which is more suitable for packing different materials.
6. positioned stop function without sticking knife and wasting film
7. Simple driving system, reliable working, convenient maintenance.
8. All control is realized through software. easy for function adjusting and technical upgrading.

### 技术规格Specifications

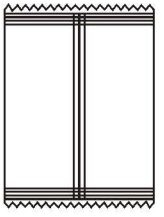
机型 (Type)	SK-W250	SK-W320	封口形式 Type of bag 
薄膜宽度 (Film width)	Max.250mm	Max.320mm	
制袋长度 (Baglength)	60-190mm 或 120-280mm	65-190mm 或 120-280mm	
制袋宽度 (Bagwidth)	30-110mm	50-160mm	
产品高度 (Product height)	Max.40mm	Max.55mm	
膜卷直径 (Film roll diameter)	Max.320mm	Max.320mm	
包装速度 (Packaging rate)	40-230bags/min	40-230bags/min	
电源规格 (Power)	220V 50/60Hz 2.6KW	220V 50/60Hz 2.6KW	
机器尺寸 (Machine size)	(L)3770 × (W)640 × (H) 1320	(L)3770 × (W)720 × (H) 1450	
机器重量 (Machine weight)	About 500kg	About 600kg	
备注 (Remarks)	可加充气装置 (Optional air filling device)		

## SK-W350回转式枕包机 (升级版)

SK-W350 Rotary pillow packaging machine(up graded)

### 适用范围Applications

适用于饼干、米通、雪饼、蛋黄派、巧克力、面包、方便面、月饼、药品、日用品、工业零件、纸盒或托盘等各类有规则物体的包装。

Packaging various kinds of regular objects like biscuits, pies, chocolates, bread, instant noodles, moon-cakes, drugs, daily appliances, industrial parts, paper boxes, plates, etc.



## SK-W450回转式枕包机 (升级版)

SK-W450 Rotary pillow packaging machine(up graded)

### 适用范围Applications

适用于饼干、米通、雪饼、蛋黄派、巧克力、面包、方便面、月饼、药品、日用品、工业零件、纸盒或托盘等各类有规则物体的包装。

Packaging various kinds of regular objects like biscuits, pies, chocolates, bread, instant noodles, moon-cakes, drugs, daily appliances, industrial parts, paper boxes, plates, etc.



### 主要结构和性能特点Features

1. 双变频器控制，袋长即设即切，无需调节空走，一步到位，省时省膜。
2. 人机界面，参数设定方便快捷。
3. 故障自诊断功能，故障显示一目了然。
4. 高感度光电眼色标跟踪，数字化输入封切位置，使封切位置更加准确。
5. 温度独立PID控制，更好适合各种包装材质。
6. 定位停机功能，不粘刀，不浪费包膜。
7. 传动系统简洁，工作更可靠，维护保养更方便。
8. 所有的控制由软件实现，方便功能调整和技术升级，永不落后。

1. Dual transducers control and bag length can be let and cut in one step.
2. Interface are easy and quick to set and operate.
3. Failures can be self-diagnosed and displays clearly.
4. High sensitivity electrical eye traces and sealing position is input numerically for accuracy.
5. PID control temperature independently which is more suitable for packing different materials.
6. positioned stop function without sticking knife and wasting film
7. Simple driving system, reliable working, convenient maintenance.
8. All control is realized through software. easy for function adjusting and technical upgrading.

### 本套机组Complete set of this machine

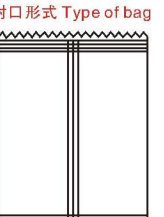
机型 (Type)	SK-W350	SK-W450	封口形式 Type of bag 
薄膜宽度 (Film width)	Max.350mm	Max. 450mm	
制袋长度 (Baglength)	65-190mm 或 120-280mm	130-450mm	
制袋宽度 (Bagwidth)	50-160mm	50-180mm	
产品高度 (Product height)	Max.60mm	Max.70mm	
膜卷直径 (Film roll diameter)	Max.320mm	Max. 320mm	
包装速度 (Packaging rate)	40-230bags/min	30-180bag/min	
电源规格 (Power)	220V 50/60Hz 2.6KW	220V,50/60HZ,2.6KVA	
机器尺寸 (Machine size)	(L)4020 × (W)745 × (H) 1450	(L)4020 × (W)820 × (H) 1450	
机器重量 (Machine weight)	About 650kg	About 900Kg	
备注 (Remarks)	可加充气装置 (Optional air filling device)		



### 组合秤 Combination weigher



十头组合秤  
10 head combination weigher



十四头组合秤  
14 head combination weigher



沙拉十四头组合秤  
Sala 14 head combination weigher



十六头组合秤  
16 head combination weigher

#### 主要结构和性能特点Features

- 1.高精度的传感器，是正确计量瞬间进行实现。
- 2.采用了步进电机，运转安静，动作稳定，寿命长。
- 3.可根据被计量物的特性，细微调整料斗门的开闭速度，防止破碎。
- 4.所有部件采用不锈钢，干净卫生。
- 5.兼容性好，易于其他包装设备配合使用。

1. With instantaneous reaching of correct calculating by high-precision load cell.
2. With quiet running, stable action and long life by adopting step motor.
3. The open & close speed of the material bucket cover can be finely regulated according to the measured material to prevent crashing and damage.
4. Neatness and hygiene by using stainless steel as the material of its parts.
5. With excellent compatibility and easy using other packing equipment.

#### 适用范围Applications

适用于薯片，锅巴等膨化食品，核桃，开心果等大壳坚果，糖果，瓜子，小饼干，果蔬片，炒货，果冻，话梅，巧克力等休闲食品，宠物食品，小五金等颗粒状，块状，条状等物料的定量称量。

It's suitable for metering the pellets, bar, granular, shape materials. Such as puffed food, candy, small biscuit, vegetable slice, nut, fried material, pet food, small hardware etc.

### 微型秤 Mini weigher



#### 功能特点 Features:

1. 出厂参数设置恢复功能。
2. 支持200G，1000G多段重量标定。
3. 缺料时可自动暂停，使称量更加稳定。
4. 显示器中自带帮助菜单，方便学习使用。
5. 可存储100套参数，实现多方面物料需求。
6. 运行中各线振幅可独立调节，可使加料更加均匀。

1. Program recovery function can reduce operation failures
2. no products auto pause function can improve weighing stability and accuracy
3. High-precision digital load cell
4. User-friendly help menu in touchscreen contributes to easy operation
5. 100 programs capacity can meet various weighing requirement
6. 15 languages available for global markets
7. Linear amplitude can be adjusted independently
8. calibration can be made with 200g and 1000g

型号 Model:	SK-A10-1-3
单次称重范围 Single weighing range	2-100G
称重精度范围 Accuracy	0.1-1.0G
最大称重速度 Max speed	600PPM
电源要求 Power requirement	220V/900W/50/60HZ/8A
包装尺寸 Packing Dimension (mm)	1200 (L) X 980 (W) X 980 (H)
包装重量 (Gauss weight)	180KG

#### 技术规格 Specifications

规格名称 (Type)	十头组合秤 10 head combination weigher	十四头组合秤 14 head combination weigher
最大称重 (Max weighing weight)	1000g	3000g
称量范围 (Weighing range)	10-800g	10-1000g
称量精度 (Weighing accuracy)	±0.3-1.5g	±0.3-1.5g
称量容量 (Weighing capacity)	最大1600cc (Max.3000cc)	最大1600cc (Max.3000cc)
称量速度 (Weighing speed)	最大60次/分钟 (Max.60bags/min)	最大120次/分钟 (Max.120bags/min)
产品预设数 (Type of weight setting)	50种 50 types	99种 99 types

规格名称 (Type)	沙拉十四头组合秤 Sala 14 head combination weigher	十六头组合秤 16 head combination weigher
最大称重 (Max weighing weight)	5000g	3000g
称量范围 (Weighing range)	10-3000g	10-800g
称量精度 (Weighing accuracy)	±1-5g	±0.3-1.5g
称量容量 (Weighing capacity)	最大3000ml (Max.3000cc)	最大1600ml (Max.3000cc)
称量速度 (Weighing speed)	最大90次/分钟 (Max.90bags/min)	最大180次/分钟 (Max.180bags/min)
产品预设数 (Type of weight setting)	99种 99 types	99种 99 types

### 四斗秤 Linear weigher



#### 主要结构和性能特点

1. 数字式传感器使精确计量瞬间得以实现。
2. 微电脑控制系统，采用双振动给料，进口仪表，技术先进，操作简便。
3. 全不锈钢密封机体，具防腐防尘之功效。
4. 计量斗能快速拆卸，便于清洗维修。
5. 可应用户要求，进行不同分装形式组合，扩大称量范围。
6. 兼容性强，易与其他包装设备配合使用。

#### 适用范围 Applications

白糖、盐、种子、大米、味精、饲料、奶粉、咖啡、黄豆、芝麻等日用食品、调味品等小颗粒状、粉状物料的定量称重。

Suitable for weighing sugar, salt, seeds, rice, monosodium glutamate, feed, milk powder, coffee, soybean, sesame, and other daily food, Spices such as small granular, powder materials quantitative weighing.

#### Features

1. Digital sensor to accurately measure moment can be realized.
2. Microcomputer control system, dual vibration feeder, import instruments, and advanced technologies, and easy to use.
3. The all-stainless steel enclosed body, the effectiveness of anti-corrosion and dust.
4. Measures to fight rapid dismantling, cleaning easy maintenance.
5. Can be user requirements, different packaging combination, and expand the scope of.
6. Strong compatibility, and easily used in conjunction with other packaging equipment.

#### 技术规格 Specifications

机型 Model	大四斗秤 Big 4 head weigher	小四斗秤 small 4 head weigher	大二斗秤 Big 2 head weigher
最大称重 weighing weight	Max 1000g	Max 100g	Max 2500g
称量速度 Weighing speed	50bag/min	70bag/min	25bag/min
称量精度 Weighing precision	±0.5g-2g	±0.5g-2g	±0.5g-2g
产品预设模式 Preset weight pattern	10种 10 types	10种 10 types	10种 10 types

### 重量选别秤 Check weigher



#### 主要结构和性能特点Features

1. 采用世界先进的数字式称重单元，实现高速、稳定计量。
2. 液晶显示触摸屏操作系统、中英文操作界面，方便易学。
3. 自我诊断功能：当Rom/Ram、A/D 光电管通讯异常时会有出错显示。

1. Apply advanced digital signal processing and realize high speed and stable weighing.
2. With liquid crystal and tangibly screen, it is easy to operate.
3. Self-diagnosis function, when Rom/Ram, A/D light electric tube.

#### 技术规格 Specifications

参数/型号 Model	标准重量分区 Standard weight subarea				
	10-99g	100-500g	501-600g	601-999g	1000-10000g
速度(包/分) Speed	65	60	50	50	45
精度(g) Accuracy	±0.5g	±0.5g	±0.5g	±1g	±2g
最小刻度(g) Minimum Scale	0.1	0.1	0.1	0.1	0.2
产品预设模式(种) Types of weight setting	10	10	10	10	10
机体尺寸(mm) Machine dimension	1050(L)X681(W)X1260(H)				
可选剔除装置 Eliminate device	吹气式/推杆式 Huff/button pole eliminate				
电压(V) Voltage	220V				
功率(W) Watt	300W				

#### 适用范围 Applications

用于检测单个产品重量与设定目标是否相符，并由分选装置自动剔除不合格标准的产品。

Use in detecting the single product weight and setting target value which is accordingly or not. And the sorting unit will eliminate the unstandard product

### 金属检测机 Metal detector



#### 主要结构和性能特点Features

1. 感应器整套使用超型；
2. 感应器整体边移，使其避免主传动件的干扰；
3. 改进后稳定性，灵敏度明显提高了一级
4. 适用于食品，玩具等的检测，能检测铁和不锈钢；
5. 铁和非铁灵敏度可调，可以检测铁、铝、不锈钢等材质；
6. 二路发光二极管分别显示铁和非铁信号大小，操作方便、直观；
7. 对水产品、速冻食品、腌制食品等的产品效应具有极强的抑制能力。

1. The whole set of sensor is the improved type
2. The whole set of sensor is moved to the side to avoid interference with the main driving components
3. The sensor distinctly enhances its stability and sensitivity after the improvement
4. It is applicable for detection on food and toys and can detect iron and stainless steel
5. The sensitivity to iron and non-iron is adjustable. it can detect different materials such as iron, aluminum and stainless steel etc
6. Two LED lights separately show the signal of iron and non-iron it is easy to operate.
7. It has strong inhibition ability to the effects of aquatic products, frozen food, Preserved food etc

#### 技术规格 Specifications

型号/Model	4042	4045	4020	4023	4028	5025
铁灵敏度 Sensitivity Fe (mm)	0.8	1.0	1.5	1.5	1.5	2.0
不锈钢灵敏度 Sensitivity Sus (mm)	1.5	2.0	3.0	3.0	3.0	3.5
探测高度 Detection height (mm)	120	150	200	230	200	250
探测宽度 Detection width (mm)	400	400	400	400	400	500
电源 Power (w)	220V, 50/60Hz, 200w					
检测速度 Belt speed (m/min)	20	20	20	20	20	20
报警方式 Alarm method	停机或排斥 (可自行选择) Alarm to stop or reject					



## 成品输送机

Finished Product Conveyor



### 主要结构和性能特点 Features

本机采用进口微型电动机传动，低噪音、寿命长，可将成品输送到平台，在包装过程中减少废品，令包装机工作顺畅。

1. Adopt imported miniature motor and featured with low noise, long life.
2. It can transport finished products to platform, reducing waste during the process.
3. Take the finished products away in time, to make packing machine work more smoothly.

### 技术规格 Specifications

功率 (Power)	40w
输送量 (Conveying capacity)	80包/分 60bag per minute
电压 (Voltage)	220V
毛重 (Gross weight)	40KG

## 出料输送机

Finished Product Conveyor



### 主要结构和性能特点 Features

1. 本机采用皮带输送，可单独使用，也可以与包装机配套完成产品输送。
  2. 可根据客户提供的数据或现场勘测进行设计，提供先进、合理、经济的整体解决方案。
  3. 可选用材型、不锈钢、碳钢喷结构，PVC 皮带、不锈钢链板，PVC 链板等输送。
1. The unit adopts belt conveyor. It can be used alone, and also can support packing machine to finish product delivery.
2. According to the data provided by the customer or site survey to carry on the design, to provide advanced, reasonable, economy overall solution.
3. Optional different materials type, stainless steel, carbon steel structure, PVC belt, stainless steel chain plate, PVC chain plate conveyor, etc.

### 技术规格 Specifications

功率 (Power)	60w
输送量 (Conveying capacity)	80包/分 60bag per minute
电压 (Voltage)	220V
毛重 (Gross weight)	50KG

## 真空上料机

Vacuum feeding machine



### 主要结构和性能特点 Features

1. 采用压缩空气，送入真空发生器，真空料斗产生真空实现配套进行加料。
  2. 占地面积小，使用方便，操作简单。节省劳动力。
  3. 整机采用搭扣式连接，拆卸方便，易清理桶内存料。
1. Using compressed air, into the vacuum generator, vacuum hopper produce vacuum to support feeding.
2. Small footprint, convenient to use, Easy operation. Saving labour.
3. The whole machine adopts hasp type connection, convenient dismantlement, easy cleaning barrel memory materials.

型号	QVC-1	QVC-2	QVC-3
输送量 (kg/h)	300	450	1200
耗气量 (升/分)	180	360	720
供气压力 (Mpa)	0.6	0.6	0.6
电压(V)/功率 (W)	220V/200W	220V/200W	220V/200W

### 适用范围 Applications

广泛用于食品业、医药业、种子业、如：白糖、味精、面粉、稻谷、板蓝根冲剂等物料输送。  
It is widely used in food, pharmaceutical, seed. Such as suger, salt, flour, rice, others granule etc.

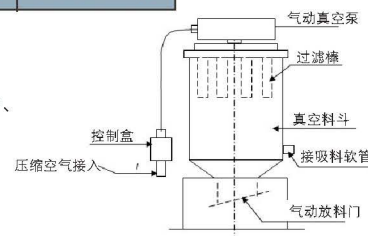

## Z型物料提升机

Z Type material elevator



### 主要结构和性能特点 Features

1. 该提升机与电子计量秤配套使用，并用控制电路以料位控制，实现自动供料和停止的自动化功能。
2. 该提升机有不锈钢材料和碳钢两种材料制作，可供客户选择。

1. The elevator and electronic metering scale shall be used together, control circuit is used to control the position of the material, realizing automatic feeding and stopping function.
2. The elevator can be made of stainless steel and carbon steel according to the customer choice.

### 适用范围 Applications

适合于各种易碎和不易碎物料提升，如薯片、虾条、锅巴、各种五金类、药品类等。  
Suitable for the lifting of frangible and nonfrangible material such as potato slice, prawn cracker, crispy rice, metals and medicines etc.

### 技术规格 Specifications

功率 (Power)	0.75kw
输送量 (Conveying capacity)	3-6m³/h
电压 (Voltage)	380v
毛重 (Gross weight)	500kg

## 螺旋送料机

Screw conveyer



### 主要结构和性能特点 Features

该机采用螺旋式送料，并且料斗可振动，防止搭桥现象。适用于输送各种粉状和小颗粒物料。  
Adopt screw conveying material and vibrate storage Suitable for conveying various powder and little pellets, such as flour, starch, coffee powder, chocolate powder, instand drink and so on

### 技术规格 Specifications

提升高度 Lifting height	2.2m 2m 2.4m 2.8m
提升量 Lifting volume	1.5-5立方米/小时 3m³/h
规格 Specification	按客户要求制作 customers' request
材质 Material	碳钢、不锈钢 carbon steel or stainless steel
技术指标 Technical index	1、被输送物尺寸、重量。 2、输送速度、高度。 1. The size and weight of the conveying material. 2. Conveying speed and height

## 大斗物料提升机

Material Elevator

### 主要结构和性能特点 Features

本机与包装机相配套，并用控制电路料位控制实现自动供料和停止功能，价格经济、减小劳动力。  
The machine is used together with packaging machine. The control circl is used to control the position of the material, realizing automatic feeding and stopping function. The machine is featured with fair price, less labour force.

### 适用范围 Applications

适用于各种易碎和不易碎物料提升，如薯片、虾条、锅巴、各种五金类、药品类等。  
Suitable for the lifting of frangible and nonfrangible material such as potato slice, prawn cracker, crispy rice, metals and medicines etc.

### 技术规格 Specifications

电压/功率 (Power)	380v/50w
输送量 (Conveying capacity)	1.2-3m³/h
电压 (Voltage)	380V
毛重 (Gross weight)	180KG
提升高度	2m/2.6m



**SK-P-3/SK-P-5/SK-P-10 制氮机**

SK-P-3/SK-P-5/SK-P-10 Nitrogen Making Machine



**主要结构和性能特点 Features**

- 1.独特的分流设计,低能耗,产氮速度快,收效大。
- 2.采用进口阀门,设备运行可靠,开机方便快捷。
- 3.结构紧凑,占地面积小,移动方便。
- 4.运行成本低,自动化程度高,无须专业基础即可方便简单操作。

**适用范围: Applications**

适用于各种物品的保鲜:例如蔬菜,水果,茶叶,膨化食品,饼干,坚果,种子,药品,药材,啤酒,饮料等得保鲜。  
Keeping fresh for various of product.Such as vegetable,fruit,tea,puffed food ,biscuits,rice,nuts,seeds, medicinal medical,bear,drink and so on.

**技术规格:Specifications**

型号 Model	SK-P-3	SK-P-5	SK-P-10
产氮量 Production Capacity	3Nm <sup>3</sup> /h	5Nm <sup>3</sup> /h	10Nm <sup>3</sup> /h
功率 Power		5W	10W
纯度 Purity		≥99.5%	
产氮压力 Production Pressure		0.1-0.65Mpa	
机器尺寸 Machine Size	(L)570x(W)570x(H)950	(L)570x(W)570x(H)1200	(L)1350x(W)1200x(H)1650

**SK-GMB-01自动定量粉剂包装机(傻瓜机型)(最实用的机型)**

SK-GMB-01 Semi-automatic powder packaging machine



**主要结构和性能特点 Features**

- 1.标准的SUS 304不锈钢材质,完全满足食品药品的要求。
- 2.免保养无噪音的齿轮减速电机(台湾品牌的搅拌电机)。
- 3.高转速无噪音的伺服电机(台湾品牌的下料电机)。
- 4.同步搅拌机构,避免漏料现象出现。
- 5.透明料仓,物料运行状况一目了然。
- 6.可开启料仓,清理卫生既方便,又简单。

**特点 Features**

- 1.可随时、随意地进行清洗无死角。
- 2.可方便地调整搅拌器的位置,使分装精度达到最佳。
- 3.可方便对搅拌器、计量螺杆、长轴等部件进行保养检修。
- 4.占地面积小、操作简单。

主机型号 Model	
包装规格 Packing Specification	2-5000g
包装速度 Packing Speed	800-3500bags/h
包装精度 Packing Accuracy	正负1% ±1%
电源、功率 Power Supply	AC220V50HZ.2000W
整机重量 Machine Weight	180Kg
主机尺寸 Machine Dimension	(L)1300X(W)650X(H)2900

**SK-L60双振盘螺丝包装机 Double vibration plates trailer screw packing machine**

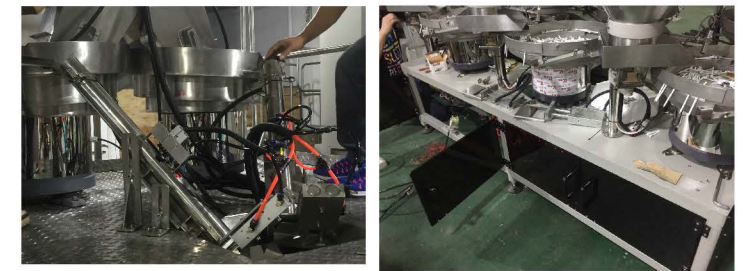

**适用范围: Applications**

广泛应用于食品行业、电工、电器、灯饰和五金建材制造业附属安装螺丝,螺钉,螺栓,螺母,垫圈,紧固件,标准件,金属产品,塑料件,橡胶件等不规则产品自动包装。  
Widely used in food industry, electric, electric appliance, lighting and metal building materials manufacturing industrial affiliated install screw, screws, bolts, nuts, washers, fasteners, standard parts, metal products, plastic, rubber parts such as automatic packaging specification products

**主要结构和性能特点 Features**

- 1.针对螺丝/异型五金件等样品量身定做的振动盘、精密的计数控制装置,确保每袋包装数量准确无误。
- 2.全自动包装机采用气动结构,使整机更安全,稳定,可靠。
- 3.先进的PLC控制系统,故障自停机、自报警、自诊断、使用安全、简便。
- 4.具有自动送料、计数、加温、包装、包装速度可调、故障显示等功能。
- 5.独特的包装封口技术,使封口美观、牢固。
- 6.该机配有链条输送拖斗,振动盘无法计量的物料可手工投放到拖斗。该机可配套多个振动盘,可同时将多种不同的物料填充到包装袋内,用户也可以选择性地使用其中的一个、两个、三个或多个振动盘。

**技术规格:Specifications**

主机型号 Model	SK-L60
生产能力 Packing rate:	30-50bag/min
计量范围 Range of measurement:	1-10粒/每台振盘
制袋尺寸 Bag size:	长(L) 50-180mm 宽(W) 40-110mm
最大膜宽 Film width:	240mm
总功率 Power:	1.2KW
净重 Net weight:	230KG
电源规格 Power Supply:	220V 50-60Hz
封边形式 Seam form:	背封 三边封
包装材料 Packing material:	纸/聚乙烯、聚酯/铝箔/聚乙烯、尼龙/聚乙烯等
主机外型尺寸 Overall dimensions:	1200 (L) × 680 (W) × 1500 (H) mm

**立式包装机可选择的配置 Optionl Device**

- 1.打码机 Printer
- 2.插角装置 Gusseting device
- 3.充气装置 Inflator equipment
- 4.打各种挂钩孔装置 Pothook/holes-punching functions (round or Euro slot/hole and others)
- 5.横封预夹装置 Pre-clamping device of horizontal seeling
- 6.横封防切料装置 Product-clip device of horizontal sealing device outside of the bag
- 7.动投卡片装置 Automatic sales promotion cardsending device
- 8.促销条卷膜装置 Automatic sales promotion filmstrip
- 9.五包半装置。 Five bags and half a bag device.

**立式包装机横封封口可选择的模式 Optional Sealing Pattern**

**一、horizontal line 横线**

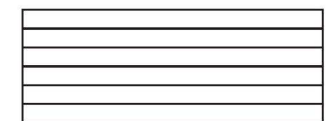

**二、Vertical Line 竖线**

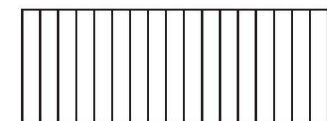

**三、Reticulate pattern 网纹**

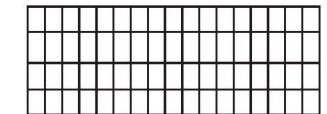



## 方案一：全自动称量包装体系

产品简介Product introduction:

该机组是一台SK-220或SK-200立式制袋 充填包装机各一台电脑多头秤组成。高精度 计量 高速度包装，人机对话、操作方便，清洗简易，可适用形状不规则、比重不一物料的全自动化包装。

The machinery group includes a vertical filling type packing machine (SK-220 or SK-200) and a computer-controlled multi-head scale, which has a high-precision, high-speed and a good man-machine interface. Easy to operate and clean. It is widely used in the food industry for packing irregular

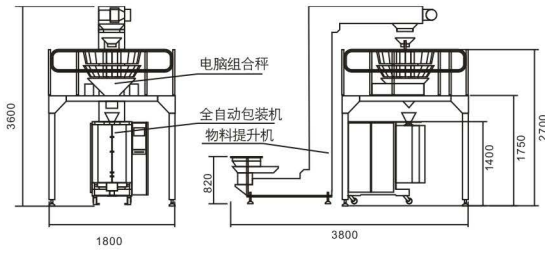

## 方案二 全自动螺旋计量体系

产品简介: Product introduction:

该机组是由一台螺旋计量和一台SK-220或SK-200立式充填包装机组成。特别适宜粉尘较大环境的超细粉状物料的计量包装。集计量、制袋、充填、封口、打印等功能于一体。配有先进的料位开关，吸尘装置。有效解决了粉尘全自动包装的难题。

The machinery group includes a vertical filling type packing machine (SK-220 or SK-200) and a screw shaft scale. It has the functions like automatic weighing, bag making and filling, sealing, and printing. Especially, it is applicable for the counting packaging of the powder-like material which has a wide dust operation environment. What is for the machine series is equipped with the advanced material-position switch and dust-collector device, which can solve the problem of automatic powder-like packaging.

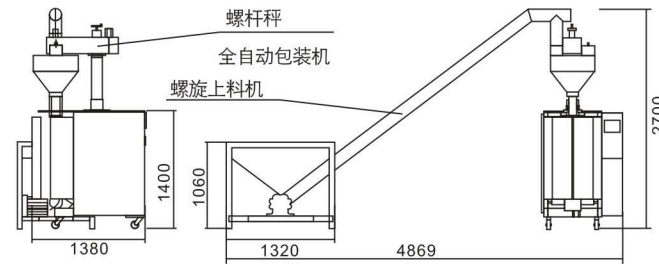

## 方案三 全自动称量人工接料包装体系

产品简介: Product introduction:

该机组主要由上料机、电子秤、平台、分料机组成。机器特点: 速度快、精度高、省人工、经济、适用! 主要针对手袋, 四边封袋, 节省装袋程序, 保护易碎产品, 提高产品质量和效率! 如需改变袋形, 可轻松的配套包装机或其它包装设备, 配套成为全自动包装体系。

The machine is mainly composed of material loader, electronic balance, and latform and material distributor. It has fast speed and high precision, saves labor and is very economical and practical. It seals four sides of the bags, shortens the procedures, protects fragile products, and improves product quality and efficiency! If the shape of bags needs to be changed, you can easily use it with other packing machines or equipments to form a full automatic packing system!

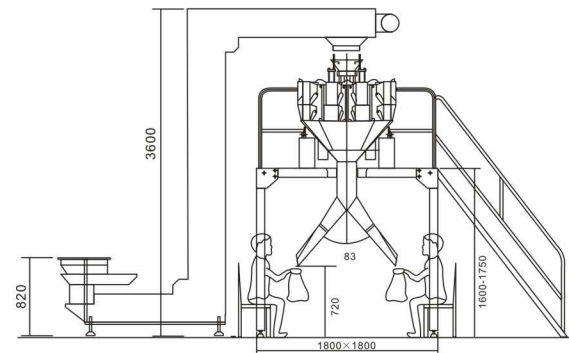

## 方案四 全自动称量人工接料包装体系

产品简介: Product introduction:

该机组主要由SK-200或SK-220包装机, 容积计量机, 大斗物料提升机, 成品输送机组成。机器特点, 整机结构简洁, 合理, 经济适用。适合于精度要求不高, 不易碎, 外形均匀的产品进行包装, 整机从上料, 计量, 打印, 充气, 制袋, 切断, 输送一次完成!

This machine is mainly composed of SK-200 or SK-220 packing machine, volume meter, large bucket material hoisting machine and conveyor. The machine has simple and reasonable structure and is very economical and practical. It is applicable for packing wellproportioned products that do not have high requirements on precision and are not fragile. The machine can complete the whole procedures such as material loading, measuring, printing, air filling, bag making, cutting and conveying in one time!

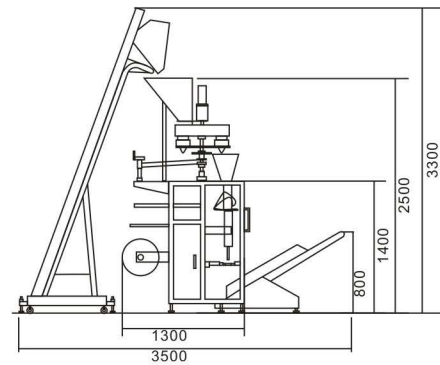

## 方案五 全自动称量输送包装体系

产品简介: Product introduction:

该机组主要由上料机、电子秤、Z型输送机、SK-200或SK-220、SK-420包装机、成品输送机组成。机器特点: 适用于厂房高度有限制、称量精度要求高、整机结构简洁、合理! 整机实现供料、称重、送料、封口、切断、打印、成品输送于一体完成。

The unit is mainly composed of feeding machine, electronic scale, Z type conveyor, SK-200 or SK-220, SK-420 packaging machine, finished product conveyor. The machine features: It is suitable for having limit at workshop height and having high requirement for Weighing accuracy. Protecting the fragile products. Realizes integration of the feeding, weighing, conveying packaging, cutting, printing, finished goods delivery to complete.

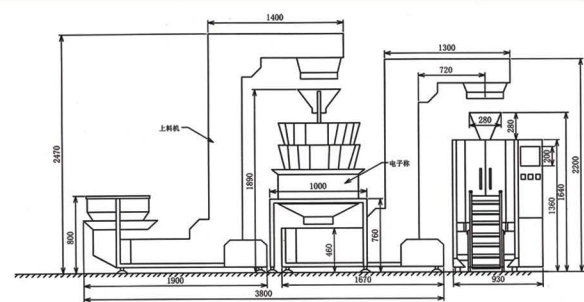

## 部份客户生产现场Production site

